

ARISTO™ EDGE 500R

WARRIOR EDGE 500

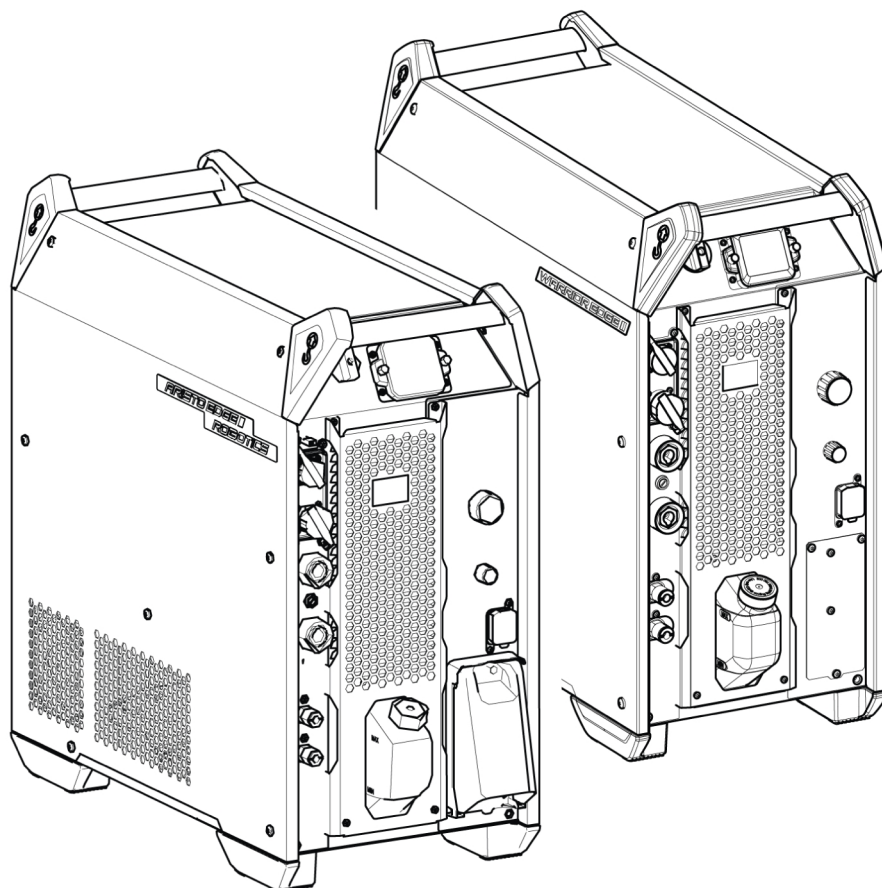

Spare parts list

Ordering no.	Denomination	Notes
0446 300 880	Warrior Edge 500	380-460 V, CX I CE
0446 300 881	Warrior Edge 500	380-575 V, CX I CSA
0446 300 882	Warrior Edge 500	415 V VRD, AUS
0446 300 883	Warrior Edge 500	380-460 V, CCC
0446 300 884	Warrior Edge 500	380-460 V, CX II CE
0446 300 887	Warrior Edge 500	380-460 V, CX II CSA
0446 300 886	Warrior Edge 500	380-460 V, DX CE
0446 300 889	Warrior Edge 500	380-575 V, DX CSA
0446 300 895	Warrior Edge 500	380-460 V, DX CCC
0446 300 890	Aristo™ Edge 500R	380-460 V, CE
0446 300 891	Aristo™ Edge 500R	380-575 V, CSA
0446 300 892	Aristo™ Edge 500R	380-460 V, CCC
0463 772 *	Instruction manual	Warrior Edge 500
0448 134 *	Instruction manual	Aristo™ Edge 500R
0463 844 001	Service manual	
0463 843 001	Spare parts list	

The three last digits in the document number of the manual show the version of the manual. Therefore they are replaced with * here. Make sure to use a manual with a serial number or software version that corresponds with the product, see the front page of the manual.

Spare parts may be ordered through your nearest ESAB dealer, see esab.com. When ordering, please state product type, serial number, denominations and ordering numbers according to the spare parts list. This facilitates dispatch and ensures correct delivery.

Maintenance and repair work should be performed by an experienced person, and electrical work only by a trained electrician. Use only recommended spare parts.

For accessories to the product, see the instruction manual.

TABLE OF CONTENTS

Housing module 4

Input module 6

Primary module 7

Transformer module 9

Secondary module current brake 11

Secondary inductor module 14

Secondary connection module 16

User interface module 18

IPS module 20

Control module 22

Cooler module 24

IoT gateway module 26

IoT gateway module - Robotics 28

Market specific module 30

SPARE PARTS

Housing module

C = Component designation in the circuit diagram					
Item	Qty	Ordering no.	Denomination	Notes	C
1	1	0446 322 880	Rear panel		
2	1	0446 330 880	Bottom panel		
3	1	0446 324 880	Front panel		
4	1	0446 723 880	Side panel left		
5	1	0446 723 881	Side panel right		
6	1	0446 344 880	Intermediate plate		
7	1	0446 328 001	Louver plate edge		
8	1	0446 332 880	Intermediate bottom		
9	1	0446 795 880	Intermediate wall rear		
10	1	0446 345 880	Intermediate cooler wall		
11	1	0446 720 880	Bracket control PCB assembly		
12	2	0465 293 001	Handle corner part	Left	
13	2	0465 293 002	Handle corner part	Right	
14	1	0465 196 001	Top panel		
15	2	0465 643 001	Power PCB bracket		
16	4	0465 415 001	Foot		
17	1	0465 331 001	Rubber mat		
18	1	0465 367 880	Louver front IP		
19	4	0194 069 003	Grommet		
20	1	0469 950 880	Cable clamp		
21	1		Rivet with flat pin		
22	1		Washer	AZ 5.3	
23	0.545 m	0192 526 002	Sealing strip	L>0.545 m, minimum order quantity is 2 m	
24	0.545 m	0192 526 002	Sealing strip	L>0.545 m, minimum order quantity is 2 m	
25	4		Screw	MC6S (IN6) M6×30	
26	4		Washer	BRB 6.4 FZB	
27	28		Blind rivets	D4×8	
28	21		Blind rivet countersunk	D4×8	
29	22		Screw	MRT M6×16, Black, cutting	
30	8		Screw	MRT M4×8 black	
31	3	0193 517 346	Screw	rx-pt 8-16×20	

SPARE PARTS

C = Component designation in the circuit diagram

Item	Qty	Ordering no.	Denomination	Notes	C
32	3	0194 153 330	Screw	Remform torx 5×16 black	
33	1		Logo decal		
34	1		OKC connector overlay	See item 101	
36	1		Main switch overlay	See item 101	
37	1	0446 306 881	Main switch overlay Aristo Edge 500R		
38	1	0464 753 001	Aristo Edge emblem		

Item	Qty	Ordering no.	Denomination	Notes
101	1	0464 663 100	Overlay kit	Including items 34 and 36

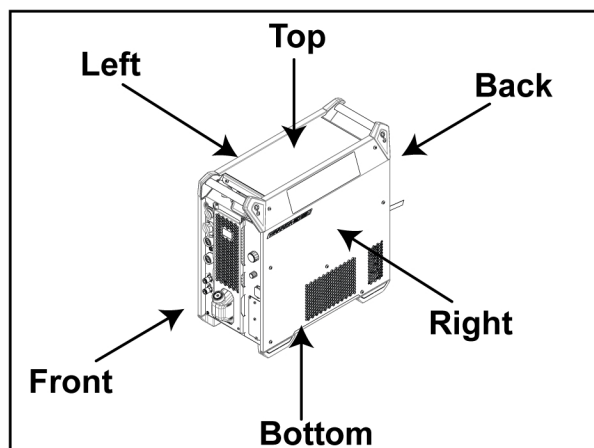
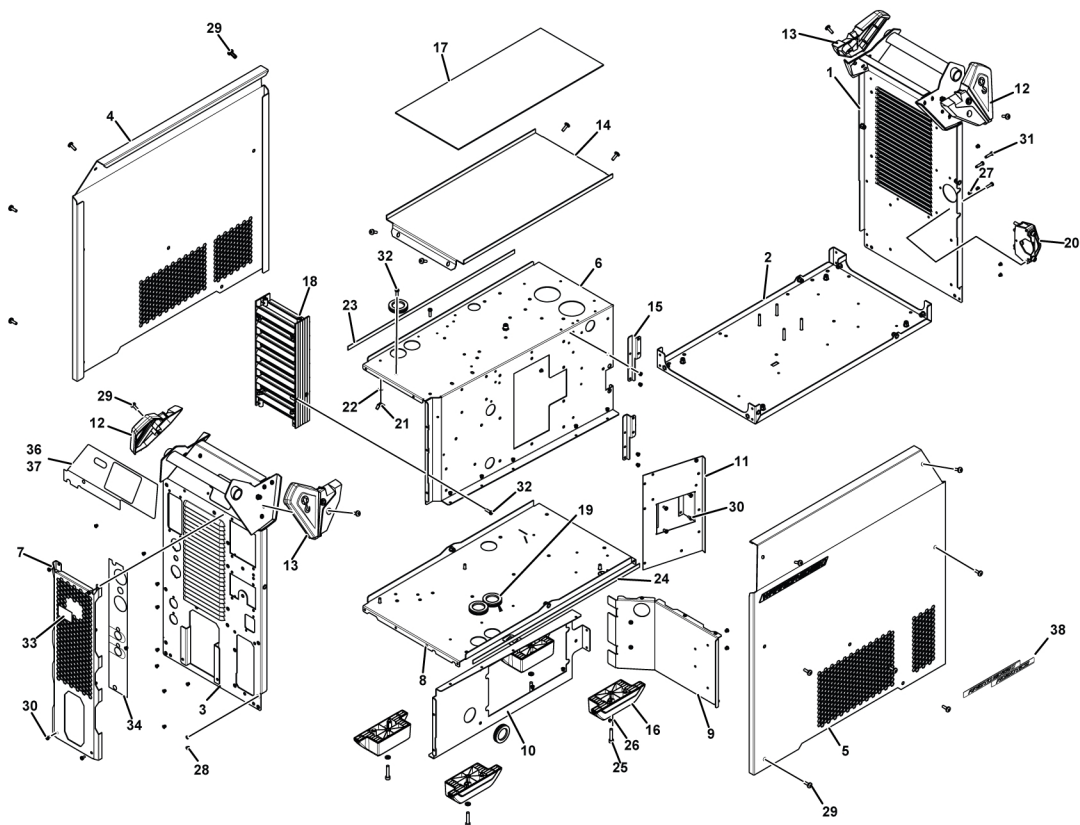

Input module

C = Component designation in the circuit diagram					
Item	Qty	Ordering no.	Denomination	Notes	C
1	1	0440 018 880	Filter PCB		2AP1
2	1		Mains switch	See item 201	2QF1
3	1		Mains switch knob	See item 201	
4	1		Mains switch gasket	See item 201	
6	1	0465 318 881	Mains switch harness		
7	5		Cable saddle		
8	3		Spacer	12.7 mm	
9	1		Nut	M6M M6 -8.8 FZB	
10	1		Washer	AZ 6.4	
11	1		Spacer screw	M4×12	
12	1		Screw	MRT M4×8	
13	2	0264 300 404	Washer for cable	KB 6.5	
14	2		Screw	MRT M3×8, see item 201	
15	1	0446 333 001	Primary inductor 40V 60%		3L1
16	4		Screw	MRT M5×8 -8.8 FZB	
17	1	0446 915 002	Protection cover Inductor		
18	2		Nut	6K STEEL 8.8 M4	

Item	Qty	Ordering no.	Denomination	Notes
201	1	0464 709 880	Input module switch kit	Including items 2, 3, 4 and 14

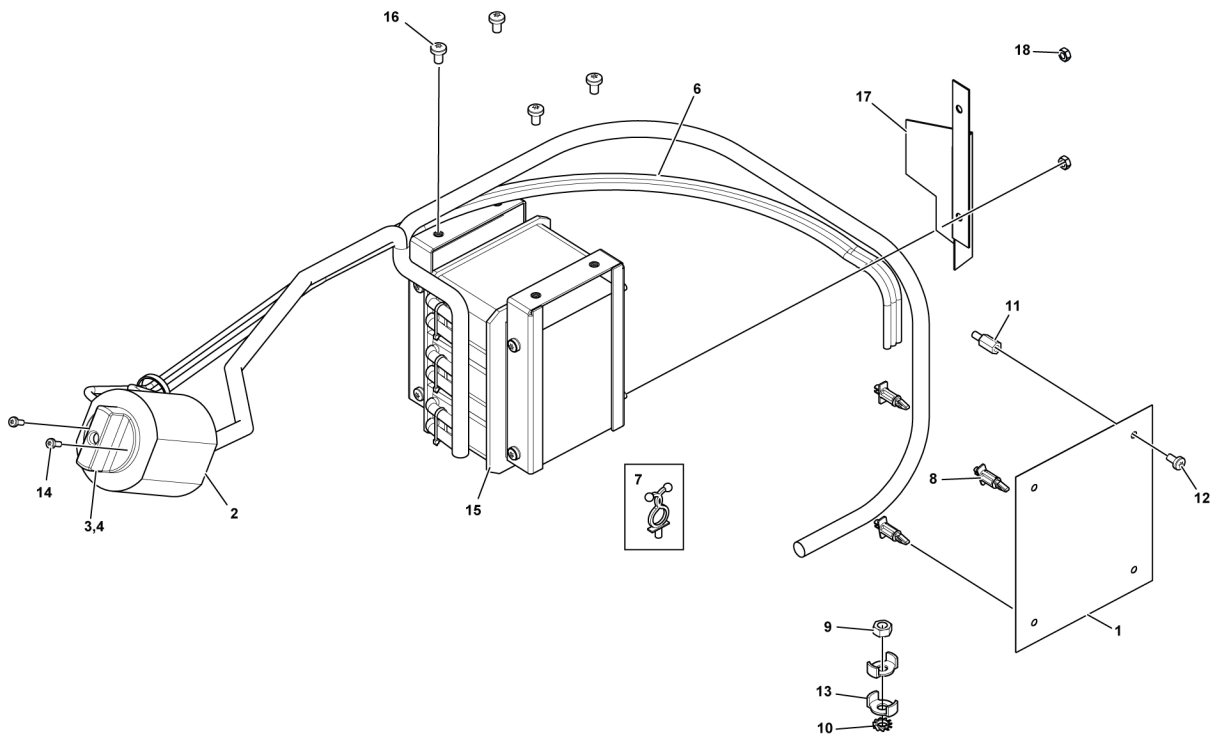

Primary module

C = Component designation in the circuit diagram					
Item	Qty	Ordering no.	Denomination	Notes	C
1	1	0465 208 001	Heat sink primary side		
2	2		IGBT module	See item 301	15PM1, 15PM2
3	1	0465 421 880	Thermo protection cable		
4	1		Rectifier bridge	SKD 82/16, see item 302	15BR1
5	1	0440 003 888	PCBA Powerboard		15AP1
6	1	0465 313 880	Gate drive harness IGBT -PCB		
7	1		Main voltage selection cable	See item 301	
8	1	0465 344 001	Fan assembly with contact	D170	15EV1
9	1	0465 332 001	Fan louver bracket rear		
10	4	0194 069 002	Grommet	27 mm	
11	14		Screw	MRT M5×8 -8.8 FZB	
12	1		Screw	MRT M4×8 -8.8 FZB	
13	14		Screw	MRT- Combi M6×16 -8.8 FZB, see item 301	
14	3	0194 153 330	Screw	Remform torx 5×16 black	
15	4		Screw	RTS ST 4.8×16 (self-tapping) FZB	
16	4		Plastic tower	LCBS-18-19 28.6mm	
17	2		Spacer screw	M4×15	
18	7		Screw	MRT- Combi M5× 10 -8.8 FZB	
19	1		Thermal protection insulation	See item 301	
20	2		Spacer LCBS	8R	
21	0.002 kg		Thermal compound	See item 301 and 302 (Apply on surfaces)	
22	6		Screw	MRT- Combi M5×12 -8.8 FZB, see item 302	
23	2	0462 178 004	Power capacitor 2200µF, 450V	Only for CE, AUS, CCC versions	15C1, 15C2, 15C3
23	2	0462 178 002	Capacitor 1500µF, 500V	Only for CSA (NA) versions	15C1, 15C2, 15C3
24	1	0440 370 881	Capacitor board		15AP4
25	1	0446 208 001	Capacitor bracket 1		

C = Component designation in the circuit diagram

Item	Qty	Ordering no.	Denomination	Notes	C
26	1	044 620 8002	Capacitor bracket 2		
27	1	044 617 4001	Capacitor foam		
28	1	0446 214 880	Capacitor harness		
29	2		Blind rivets	D4×8	
30	2		Cable saddle	Bantam	
31	1		Harness for Warrior PCBA		

Item	Qty	Ordering no.	Denomination	Notes
301	1	0464 503 880	IGBT module kit	Including items 2, 7, 13, 19 and 21
302	1	0464 504 880	Rectifier kit	Including items 4, 21 and 22

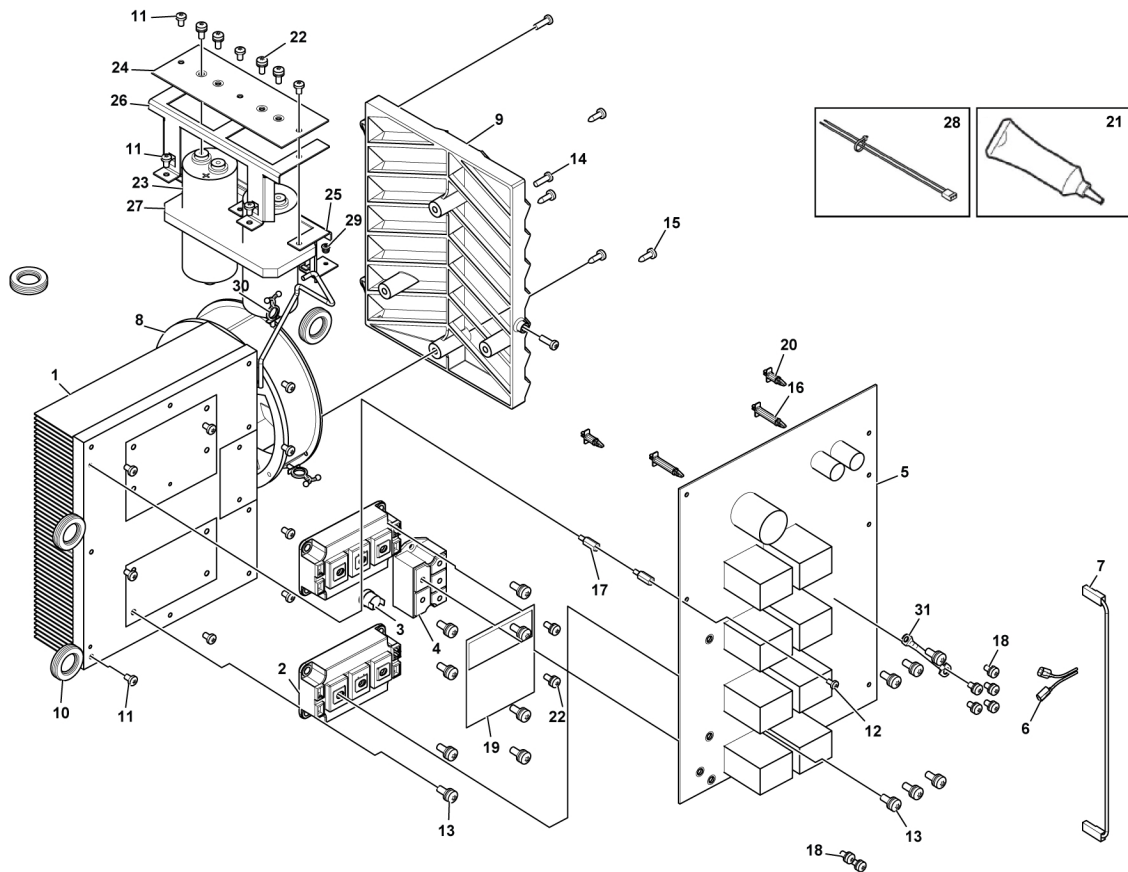

Transformer module

C = Component designation in the circuit diagram					
Item	Qty	Ordering no.	Denomination	Notes	C
1	1	0465 302 880	Transformer complete (7:1) 380-460 V	Only for CE, AUS & CCC versions	15T1
1	1	0465 302 881	Transformer complete (9:1) 380-575 V	Only for CSA (NA) version	
2	8	0194 034 005	Ferrite core	30×20×10	2L1,2L2, 2L3
3	4		Cable tie		
4	1	0465 287 880	Secondary rectifier harness transformer to diodes		
5	4		Screw	MRT M5×8 -8.8 FZB	
6	2		Washer	BRB 5.3 FZB	
7	4		Screw	MRT- Combi M5×10 -8.8 FZB	
8	4		Washer	BRB 6.4 FZB	
9	4		Spring washer	D11,8/6,1	
10	4		Screw	M6S M6×12 FZB	

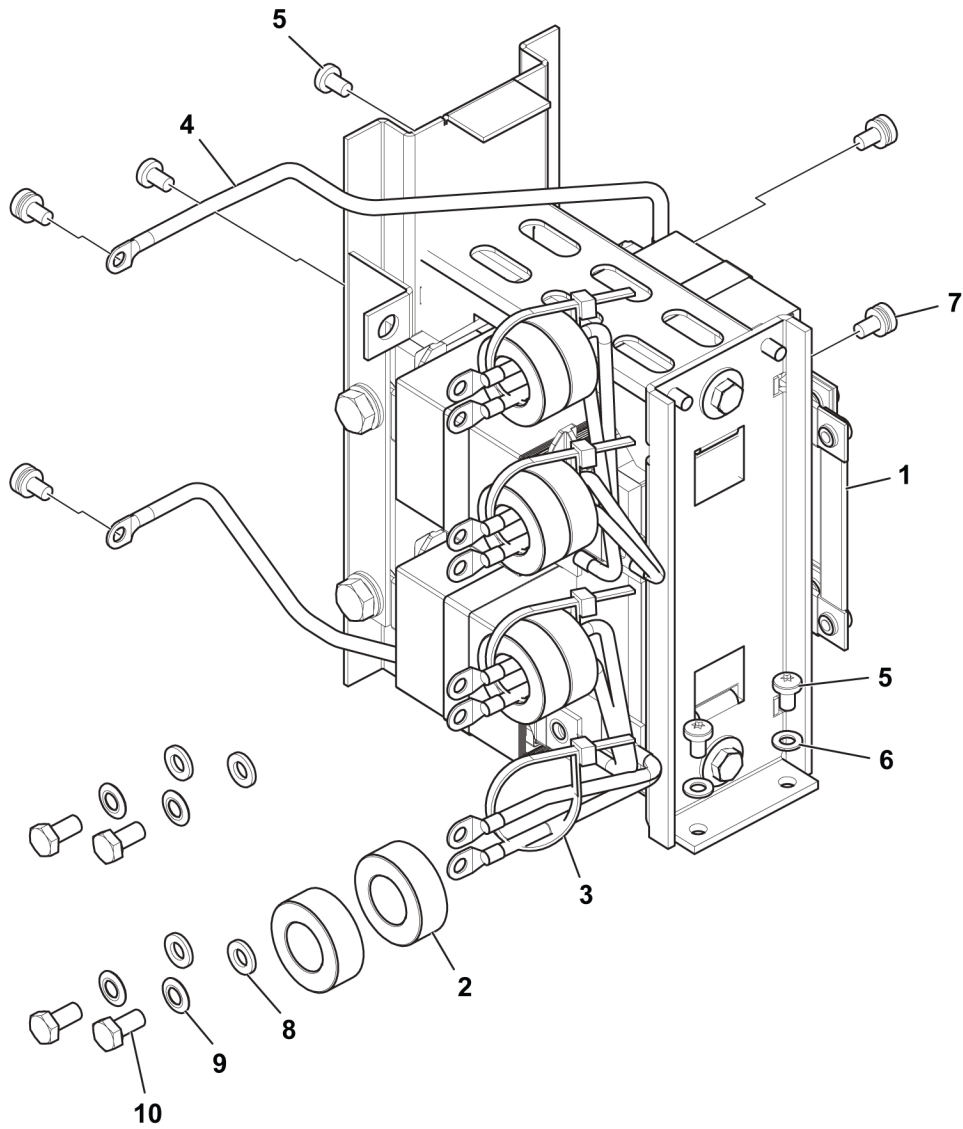

Secondary module current brake

C = Component designation in the circuit diagram					
Item	Qty	Ordering no.	Denomination	Notes	C
1	1	0465 208 006	Heat sink secondary side current brake		
2	4		Diode 400V/2×140A (incl. Screws)	See item 401	27PM1, 27PM2, 27PM3, 27PM4
3	1	0465 421 886	Thermo protection cable		
4	1		Fan foam current brake	See item 405	
5	1	0465 320 880	Ground cable		
6	2		Washer	AZ 5.3	
7	9		Nut	M6MF M5 -8.8 FZB	
8	14		Screw	MRT M5×8 -8.8 FZB	
9	16		Screw	MRT M4×8, see item 401 and 402	
10	16		Cup spring	A-8-1, see item 401 and 402	
11	4	0465 209 001	Heat-sink support		
12	1	0446 601 001	Air duct fan side		
13	4		Screw	MRT M5×12 -8.8 FZB	
14	2	0194 153 330	Screw	Remform torx 5×16 black	
15	0.002 kg		Thermal compound	See item 401 and 403	
16	1		Cable saddle		
17	1		Copper bar upper diodes	See item 402	
18	1		Copper bar lower diodes	See item 402	
19	1		Copper bar drain	See item 404	
20	1		Copper bar source	See item 404	
21	1		Copper bar anode	See item 404	
22	1		Fan with contact	See item 405	27EV1
23	1	0446 317 880	Bracket resistor inner assy		
24	1	0446 557 880	Bracket resistor inner angled assy		
25	2	0446 315 880	Bracket resistor outer assy		
26	1	0446 914 880	Current brake resistor harness		
27	1		PCBA current brake	See item 403	27AP1
28	2		Power mosfet module	See item 403	27PM5, 27PM6
29	3	0194 069 003	Grommet		

SPARE PARTS

C = Component designation in the circuit diagram					
Item	Qty	Ordering no.	Denomination	Notes	C
30	1		Nomex current Brake		
31	1		Screw	M6S 8×20, see item 402	
32	2		Washer	BRB 8.4 FZB, see item 402	
33	2		Cup spring	16/8.2, see item 402	
34	1		Nut	6K steel 8.8 M8, see item 402	
35	8		Screw	MRT Combi M5×16, see item 403	
36	9		Spacer screw	M5×14, see item 403 and 404	
37	10		Screw	MRT Combi M5×10, see item 403 and 404	
38	2		Blind rivets	D4×8	
39	1	0446 470 880	Ribbon cable, current brake board	Connected between current brake board & control board	
40	1	0446 602 001	Air guide heatsink		
41	1	0446 603 001	Air guide current brake		

Item	Qty	Ordering no.	Denomination	Notes
401	1	0464 505 880	Diode set	Including items 2 (4 qty), 9 (8 qty), 10 (8 qty) & 15 (4x0.002 kg)
402	1	0464 712 880	Upper and lower diodes kit	Including items 9 (8 qty), 10 (8 qty), 17, 18, 31, 32 (2 qty), 33 (2 qty) and 34
403	1	0464 713 880	Mosfet kit	Including items 15 (2 qty), 27, 28 (2 qty), 35 (8 qty), 36 (4 qty) and 37 (5 qty)
404	1	0464 714 880	Copper bar kit	Including items 19, 20, 21, 36 (5 qty) and 37 (5 qty)
405	1	0464 715 880	Fan current brake kit	Including items 4 and 22

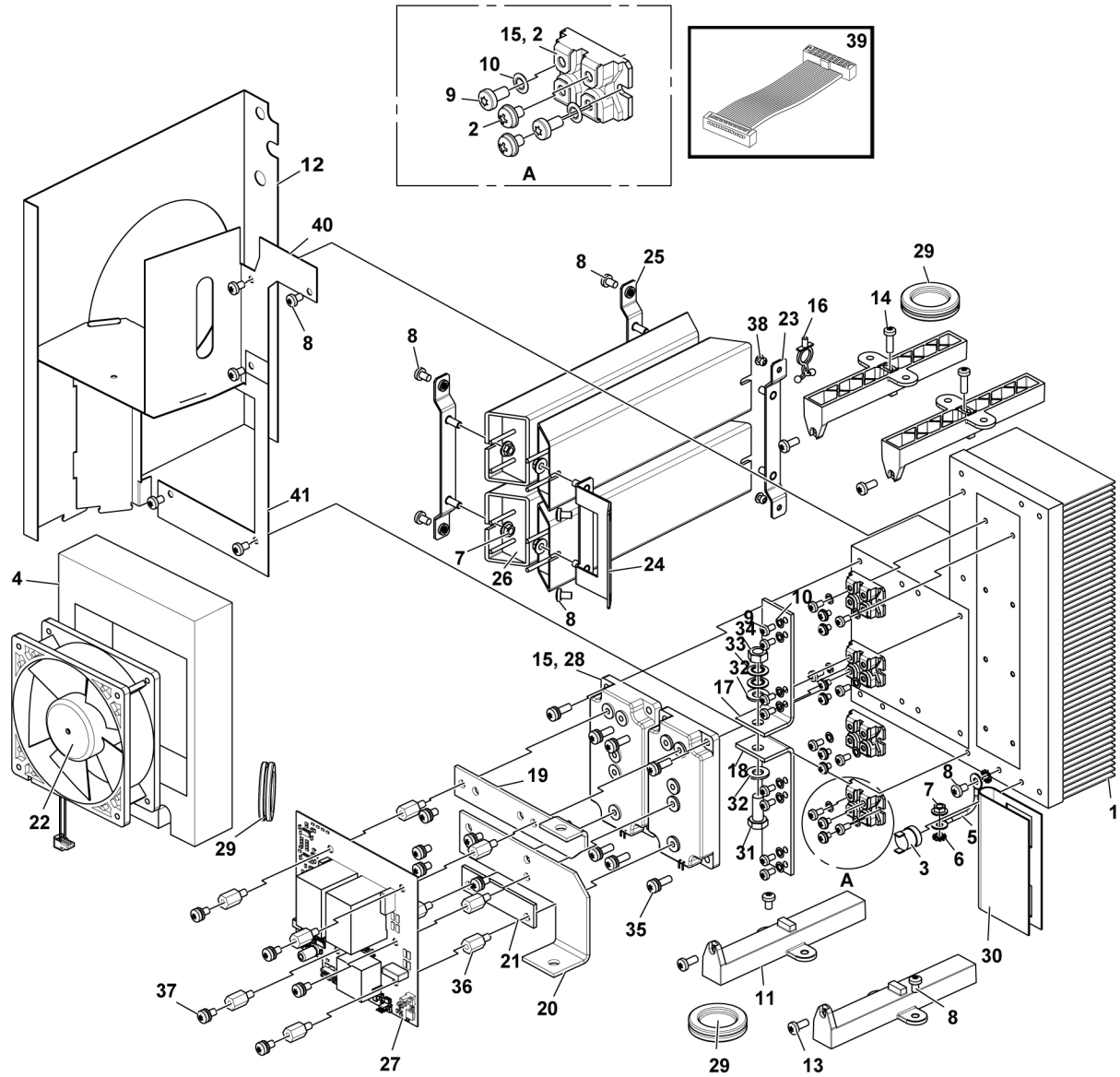

Secondary inductor module

C = Component designation in the circuit diagram					
Item	Qty	Ordering no.	Denomination	Notes	C
1	1	0465 311 880	Secondary inductor	Only for CE, AUS, CCC versions	15L1
1	1	0465 311 881	Secondary inductor	Only for CSA (NA) version	
2	1		Nut	M6M, M8 Steel 8.8	
3	2		Screw	M6S, M8×20	
4	4		Cup spring	16/8.2×0.9	
5	3		Washer	BRB, 8.4 FZB	
6	2		Nut	M6M, M5 Steel 8.8	
7	2		Washer	BRB, 5.3 FZB	
8	7		Screw	MRT, M5×8-8.8 FZB	

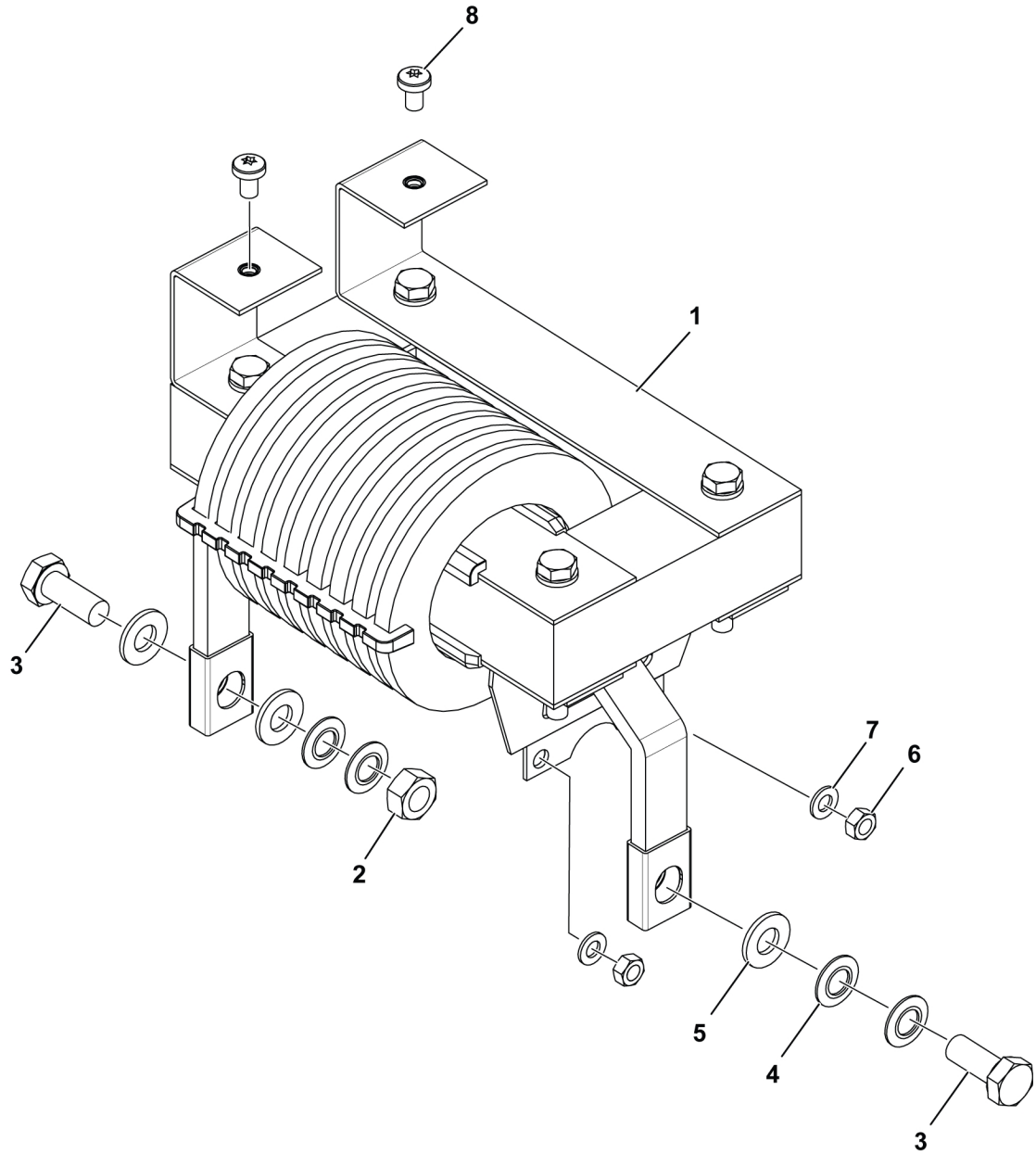

Secondary connection module

C = Component designation in the circuit diagram					
Item	Qty	Ordering no.	Denomination	Notes	C
1	2	0160 362 881	OKC 50 cable connection female		
2	1		Rail secondary inductor	OKC, see item 501	
3	1		Nut clinching	M8, see item 501	
4	1		Rail diodes	OKC, see item 501	
5	0.09 kg		Insulation rail secondary inductor	OKC, See item 501	
6	1	0463 082 881	Capacitor complete		
7	2		Washer	BRB 10.5 FZB, see item 501	
8	4		Cup spring	M10, see item 501	
9	2		Flat pin connector	M10 6.3×0.8 (2 pin), see item 501	
10	2		Screw	M6S M10×20 -8.8 FZB, see item 501	
11	1		Screw	M6S 8×20, see item 501	
12	2		Cup spring	16/8.2, see item 501	
13	2		Washer	BRB 8.4 FZB, see item 501	
14	1		Nut	6K steel 8.8 M8, see item 501	
15	1		Nut	M6MF M5 -8.8 FZB	
16	2		Washer	AZ 5.3	
17	1	0458 063 001	Current sensor		15CS1
18	1	0465 588 001	Distance		
19	2		Screw	MRT M4×8	
20	1	0465 606 881	VRD kit rev. polarity		

Item	Qty	Ordering no.	Denomination	Notes
501	1	0464 716 880	Secondary connection module kit	Including items 2-5, 7-14

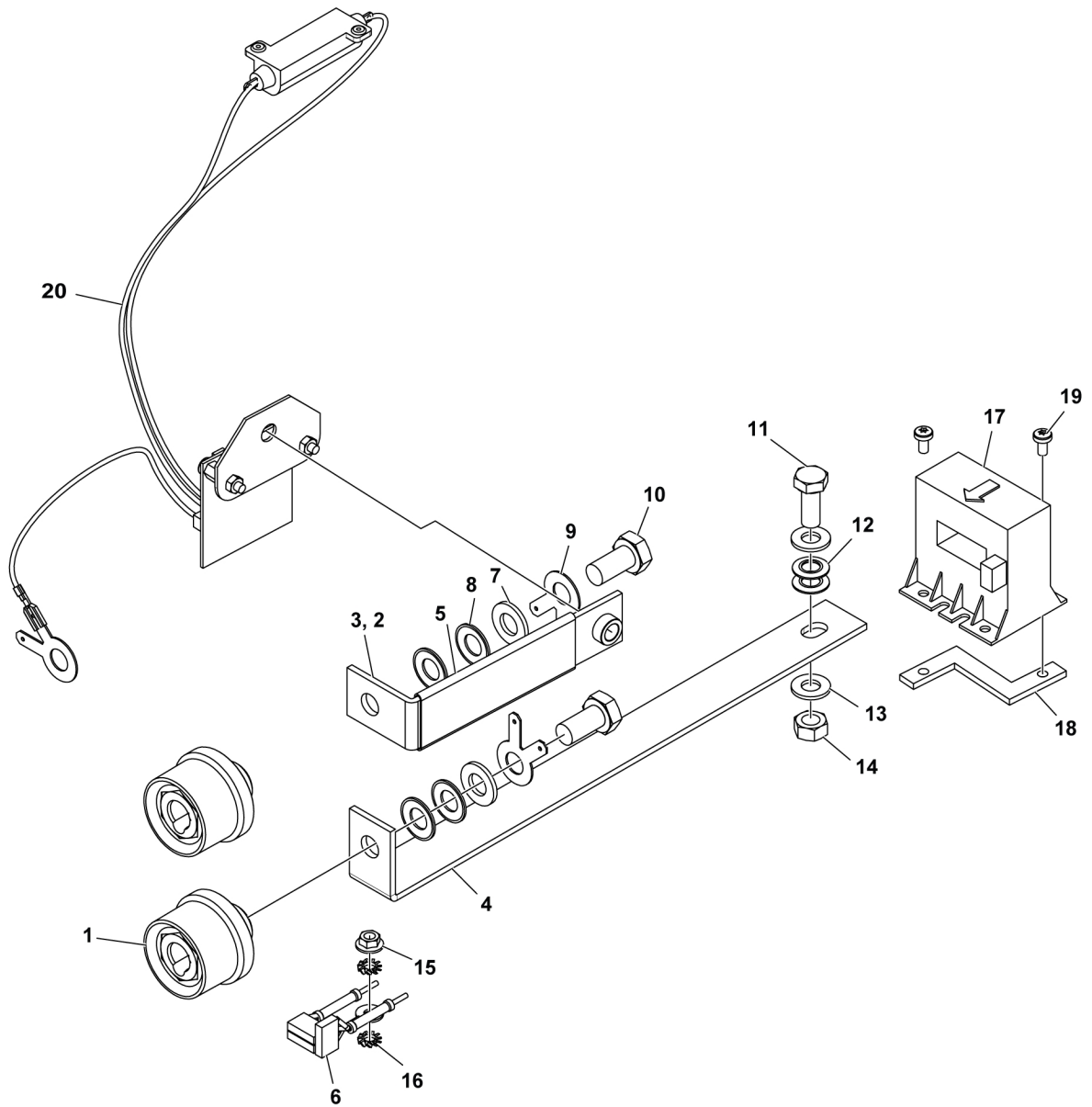

User interface module

C = Component designation in the circuit diagram					
Item	Qty	Ordering no.	Denomination	Notes	C
1	1		External UI frame	See item 601	
2	1		PCBA HMI	See item 601	1AP1
3	1		PS HMI diffusor 1	See item 601	
4	1		PS HMI diffusor 2	See item 601	
5	2		Encoder harness	See item 601	
6	1	0321 475 893	Knob	D36-1/4IN	
7	1	0321 475 892	Knob	D21-1/4IN	
8	7		Nut	6K steel 8.8 M4, see item 601	
9	1	0446 824 880	HMI cable harness		
10	1	0446 488 001	PS HMI overlay		
11	1		Washer	BRB 3.2 FZB	
12	1		Nut	6K steel 8.8 M3	

Item	Qty	Ordering no.	Denomination	Notes
601	1	0464 717 880	User interface kit	Including items 1, 2, 3, 4, 5, and 8

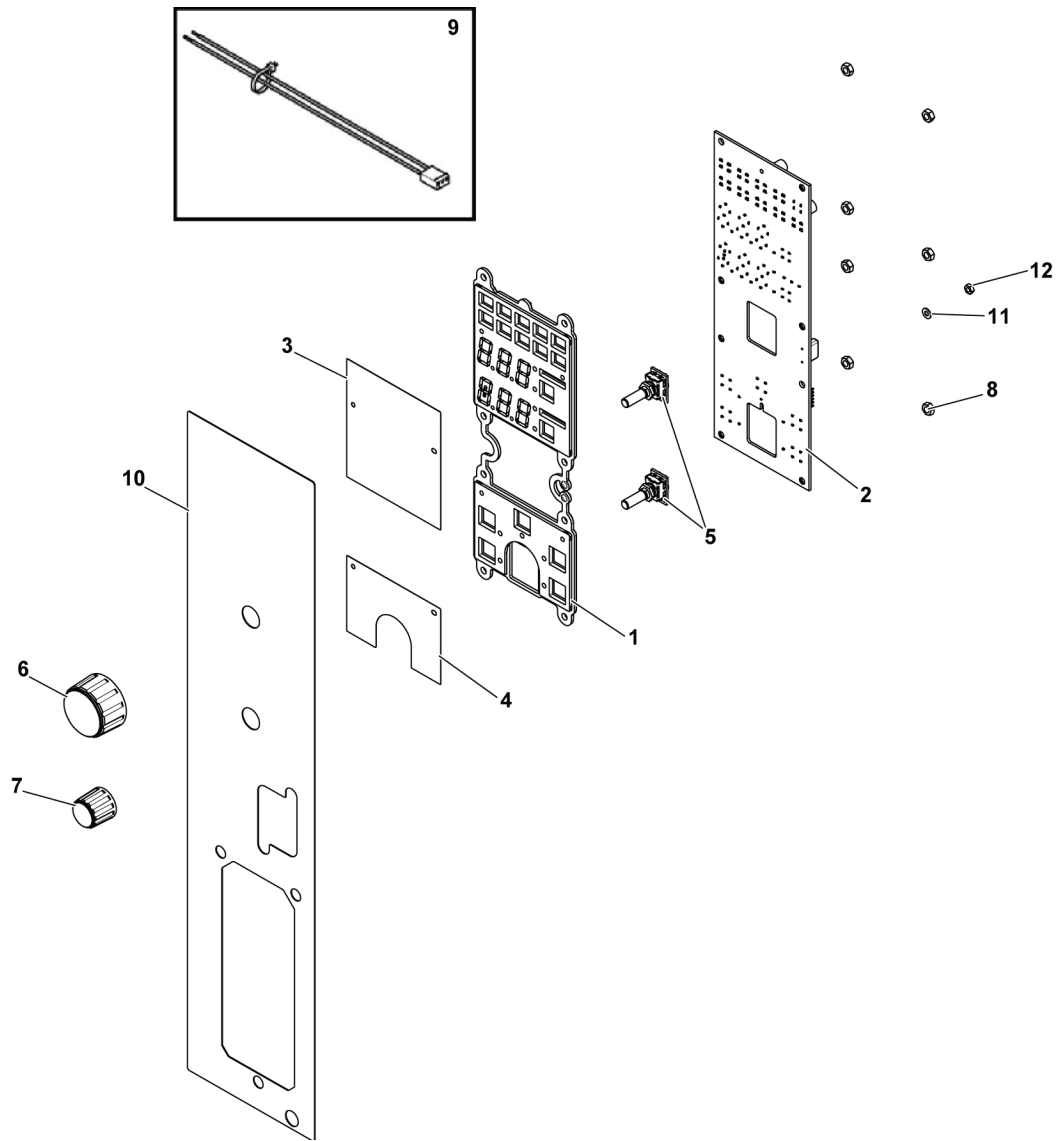

IPS module

C = Component designation in the circuit diagram					
Item	Qty	Ordering no.	Denomination	Notes	C
1	1	0465 323 004	Aux. transformer (Only for CE, AUS & CCC versions)	Includes insulation, washer and cable	2T1
1	1	0465 323 005	Aux. transformer (Only for CSA version)	Includes insulation, washer and cable	
2	1		Screw	M6S M8×65 -8.8 FZB	
3	1		Washer	TBRB D16/8,4×3	
4	1	0465 583 001	Bracket aux. transformer		
5	4		Cable saddle		
6	1	0440 021 881	PCBA IPS board cooler		15AP2
7	1	0446 912 880	DC Choke harness		15L2
8	1	0446 473 880	Power board harness		
9	1	0194 636 002	Bridge rectifier	1000V 40A	15BR2
10	1		Screw	MRT M5×16 Black	
11	1		Spacer screw	M4×12	
12	3		Spacer	9.5 mm	
13	3		Screw	MRT M4×8	

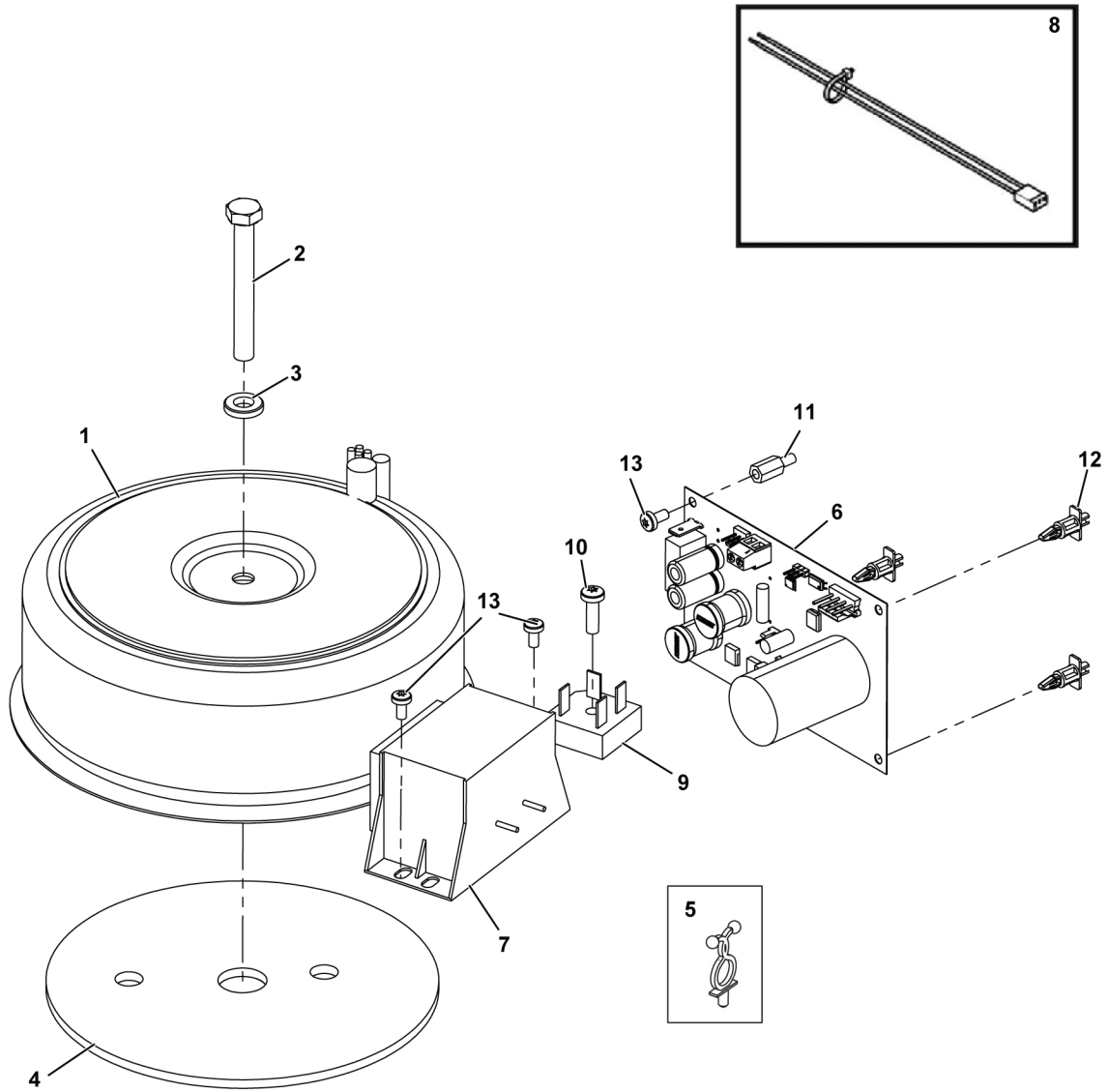

Control module

C = Component designation in the circuit diagram					
Item	Qty	Ordering no.	Denomination	Notes	C
1	1	0447 767 880	Control board	CX I CE	20AP1
		0447 767 881		CX I CSA	
		0447 767 884		CX II CE	
		0447 767 887		CX II CSA	
		0447 767 882		CX I AUS	
		0447 767 883		CX I CCC	
		0464 751 063		DX CE	
		0464 751 064		DX CSA	
		0464 751 065		DX AUS/RCM	
		0464 751 066		DX CCC	
		0464 752 217		Aristo 500 CE	
		0464 752 218		Aristo 500 CSA	
		0464 752 219		Aristo 500 CCC	
1A	1		Lithium coin battery CR2450	Manganese dioxide CR2450 3V 620 mAh (part of control board)	
2	2		Spacer screw	M4×15	
3	5		Spacer	12.7 mm	
4	2		Screw	MRT M4×8	
5	1	0446 471 881	Chassis connector harness		
6	4		Screw	Remform torx 5×16 black	
7	5		Nut	6K steel 8.8 M3, see item 702	
8	1	0446 843 001	Protection cap	25.4	
9	1	0446 844 001	Protection cap	30.8	
10	1		FEU panel mount 3AG fuse holder	See item 701	
11	1		FEU, FAU, FACfuse holder cap	See item 701	
12	1	0445 847 880	USB complete		
13	1	0465 329 880	Flat cable assembly	20-pole	
14	1		Remote connector harness	See item 702	
15	3		Cable saddle		
16	2		Screw	MRT M2,5×12	
17	1		ACDC fuse	10A 250V SUT-H	
18	1		Washer	AZ 3.2	
19	2		Washer	BRB 5.3 FZB	
20	1	0447 028 001	Connector plastic adapter		

SPARE PARTS

C = Component designation in the circuit diagram

Item	Qty	Ordering no.	Denomination	Notes	C
21	5		Screw	MRT M3×12, see item 702	
22	3		Screw	RTS ST3.5×9.5	
23	2	0467 911 884	Capacitor		
24	1		Peripheral grounding plate	See item 702	
25	1		Backshell shrinkboot adapter	See item 702	

Item	Qty	Ordering no.	Denomination	Notes
701	1	0464 718 880	FEU Fuse holder kit	Including items 10 and 11
702	1	0464 663 122	Remote connector kit	Including items 14, 21, 24, 7 and 25

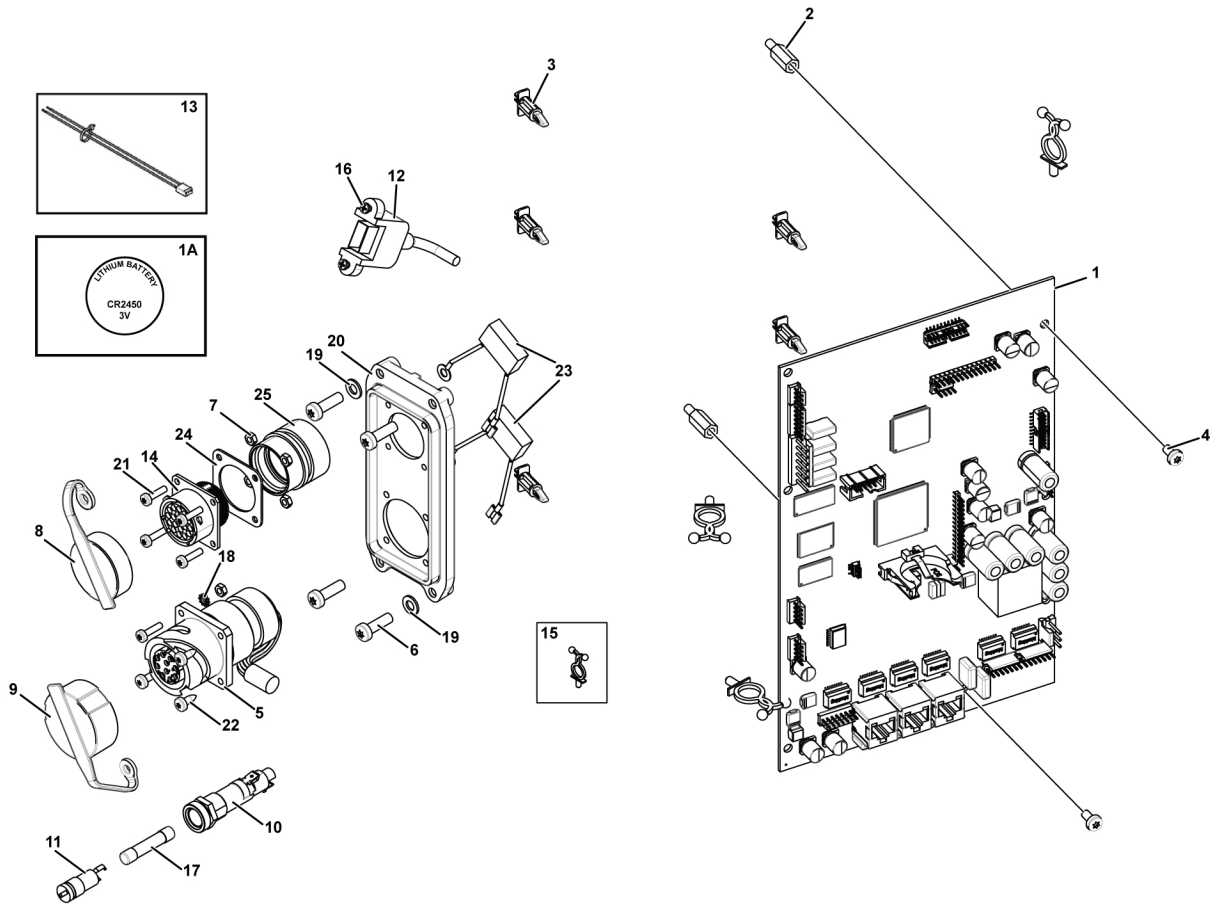

Cooler module

C = Component designation in the circuit diagram					
Item	Qty	Ordering no.	Denomination	Notes	C
1	1		Tank assembly	See item 802	
2	1	0446 331 001	Radiator		
3	1	0446 339 001	Plate cooler fan		
4	2	0462 316 882	Fan complete		5EV1, 5EV2
5	1	0446 576 880	Pump assembly		
6	1		Cooler connector plate assy	See item 801	
7	2		Quick-coupling female	See item 801	
8	1	0446 778 001	Tank bracket		
9	0.3m		Hose	See item 803	
10	0.6m		Hose	See item 803	
11	0.45m		Hose	See item 803	
12	0.8m		Hose	See item 803	
13	8		PCE hose clamp	18.5/17.8, see item 801, 803	
14	1		Sticker cooling liquid	See item 804	
15	1	0446 575 880	Cooler PCBA bracket assembly		
16	1	0440 470 880	PCBA cooler control		5AP3
17	1	0440 021 881	PCBA IPS board cooler		5AP2
18	1	0445 025 881	Thermal sensor harness		
19	1	0446 477 880	Cooler harness		
20	7		Spacer screw	M4×12	
21	9		Screw	MRT M4×8 black, see item 801	
22	4		Nut	M6MF M5 -8.8 FZB	
23	4		Screw	RTS ST5.5×16	
24	8		Screw	MRT M5×10 black	
25	1		Tank foam side	See item 802	
26	1		Tank foam top	See item 802	
28	4.7 L	0465 720 002	Coolant liquid		
29	3		Spacer	LCBS-6-19	
30	1		Rubber inlet		
31	1		Screw	MRT M3×8	
32	2		Cable tie	See item 803	
33	1	0446 949 001	Shielding plate cooler PCBA		

SPARE PARTS

C = Component designation in the circuit diagram

Item	Qty	Ordering no.	Denomination	Notes	C
34	1		Cap for tank	See item 804	
35	1	0447 695 880	Flow guard complete assembly		
36	1	0447 628 880	Flow guard bracket complete		

Item	Qty	Ordering no.	Denomination	Notes
801	1	0464 719 880	Connector kit	Including items 6, 7, 13 (2 qty) and 21 (2 qty)
802	1	0464 720 880	Tank kit	Including items 1, 25, 26 and item 804
803	1	0464 721 880	Hose kit	Including items 9, 10, 11, 12, 13 and 32
804	1	0447 044 880	Sticker and cap kit	Including items 14 and 34

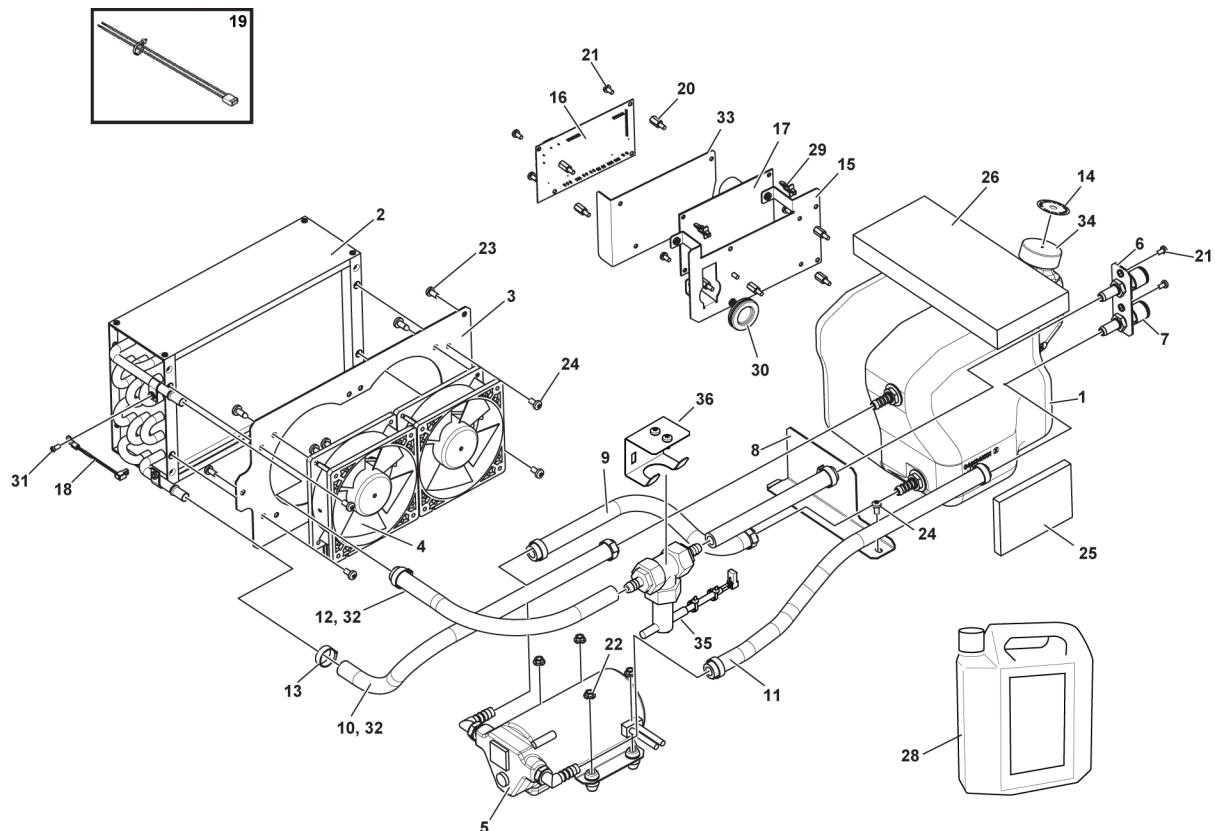

IoT gateway module

C = Component designation in the circuit diagram					
Item	Qty	Ordering no.	Denomination	Notes	C
1	1	0446 730 002	Front plate GW		
2	2	0446 732 001	PCB bracket		
3	1	0440 515 880	IoT PCBA		25AP1
4	1		USB bay	See item 901	
5	1		Lid for USB	See item 901	
6	1	0465 795 001	Ethernet connector		25XS1
7	1	0445 387 880	PCBA grounding harness		
8	2	0445 847 881	USB complete		25XS2, 25XS3
9	1		Gateway decal (USB)	See item 901	
10	2		Thumb screw	See item 901	
11	3		Screw	MRT M5×12, Black, cutting	
12	4	0194 153 289	Screw	Remform torx 4×10	
13	2	0194 153 330	Screw	Remform torx 5×16 black	
14	6	0194 153 292	Screw	Remform torx 4×12 black	
15	1	0446 822 880	Cable harness IoT GW		
16	1	0446 872 880	Ethernet cable harness		
17	1		Nut	M6MF M5 -8.8 FZB	
18	2		Washer	AZ 5.3	
19	1	0447 018 002	Ethernet connector adapter		
20	1	0465 796 001	Protective cap and seal		

Item	Qty	Ordering no.	Denomination	Notes
901	1	0464 723 880	Gateway USB kit	Including items 4, 5, 9 and 10

SPARE PARTS

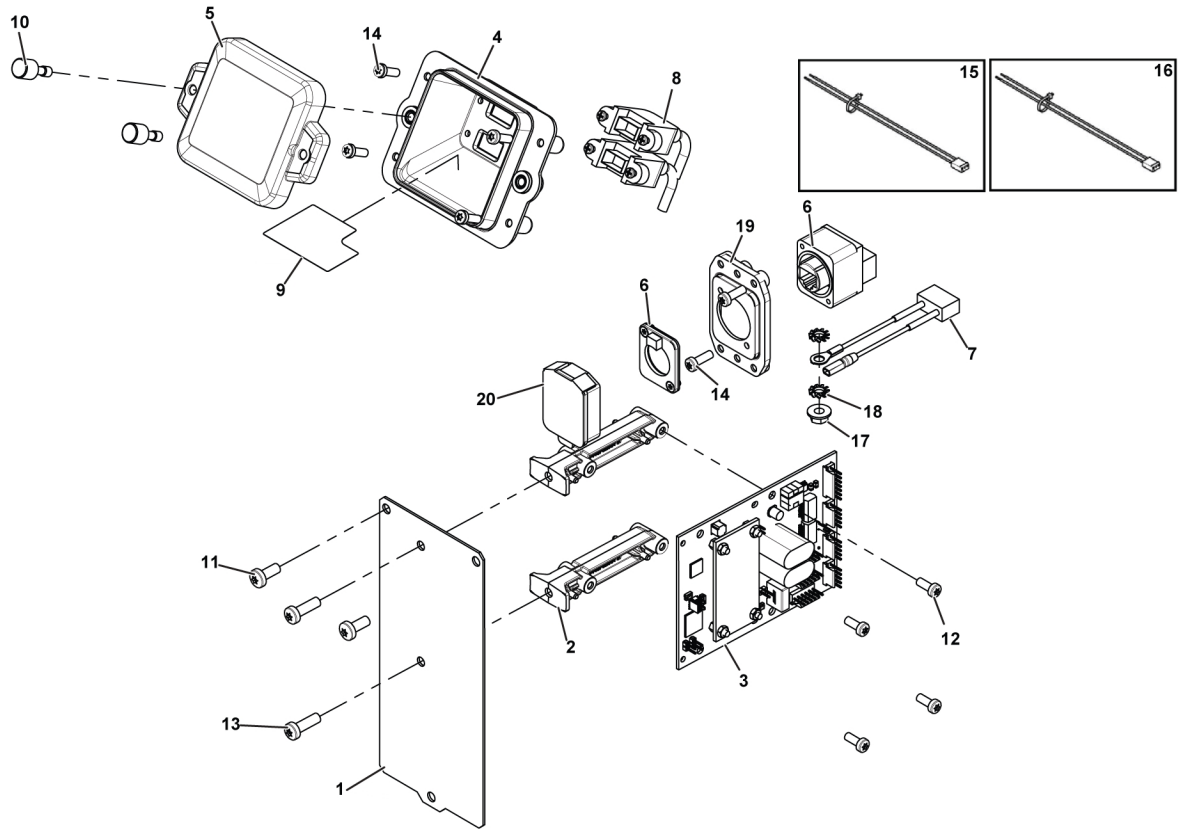

IoT gateway module - Robotics

C = Component designation in the circuit diagram					
Item	Qty	Ordering no.	Denomination	Notes	C
1	1		Gateway house		
2	2	0446 732 001	PCB Bracket		
3	1	0440 515 880	IoT PCBA		25AP1
4	1		USB bay		
5	1		Lid for USB		
6	2	0465 795 001	Ethernet connector		25XS1
7	1	0445 387 880	PCBA Grounding Harness		
8	2	0445 847 881	USB complete		25XS2, 25XS3
9	1		Gateway Decal (USB)		
10	3		Thumb Screw		
11	3		Screw	MRT M5×12, Black, cutting	
12	8		Screw	Remform torx 4×10	
13	2		Screw	Remform torx 5×16 black	
14	6		Screw	Remform torx 4×12 black	
15	1	0446 822 880	Cable harness IoT GW		
16	1	0446 872 880	Ethernet cable harness		
17	1		Nut	M6MF M5 -8.8 FZB	
18	2		Washer	AZ 5.3	
19	1	0447 018 002	Ethernet connector Adapter		
20	1	0465 796 001	Protective cap and seal		
21	1	0447 542 001	Gateway hood		
22	1	0440 564 880	Automation gateway board		25AP2
23	1		Information sign Remove		
24	1	0447 539 880	Touch sense harness		
25	4		Screw	RTS ST3,5x9,5	
26	1	0446 822 881	GW cable harness		
27	1	0462 017 001	RJ45 cable		
28	2		Nut	6K Steel 8.8 M5	

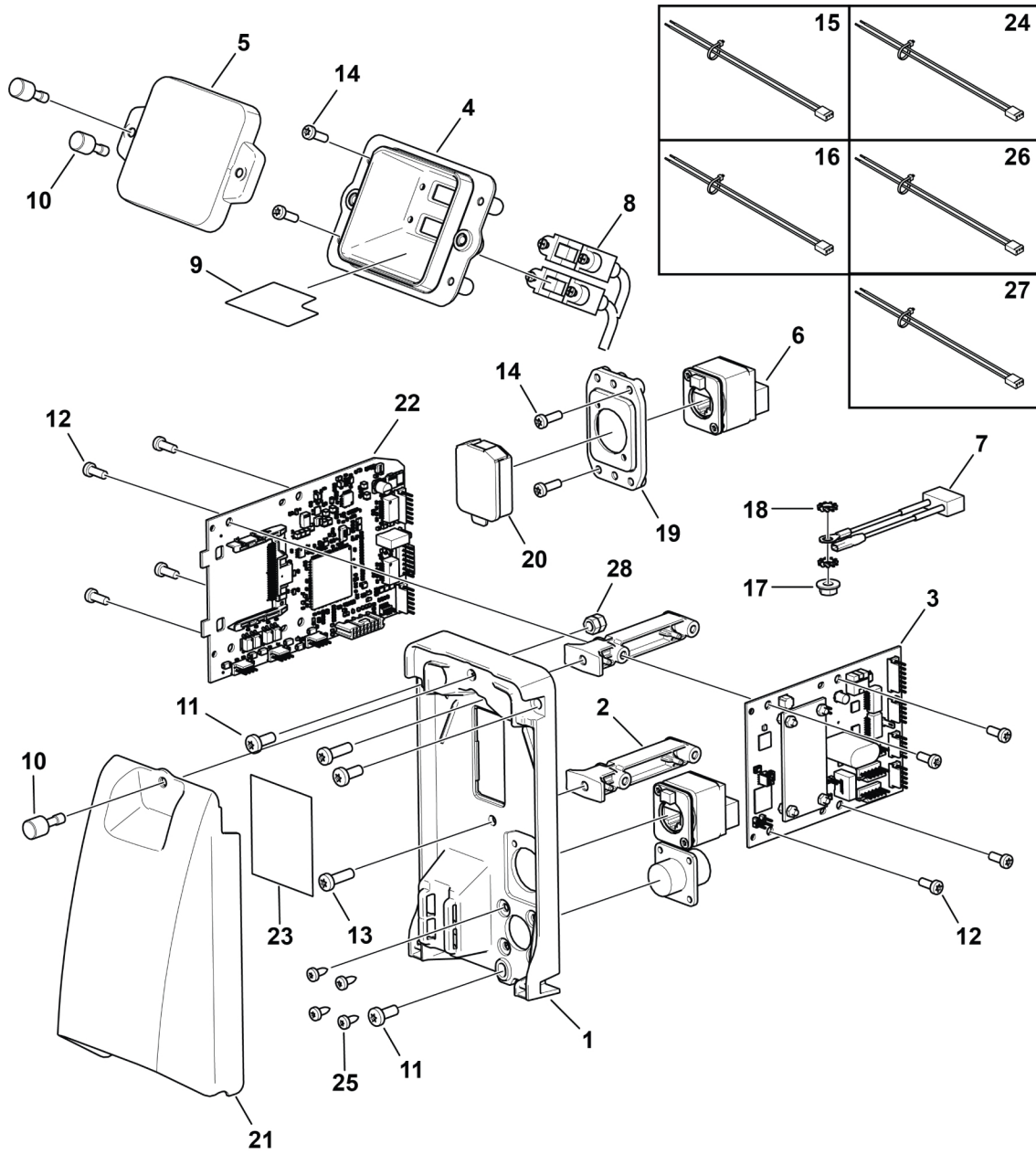

Market specific module

C = Component designation in the circuit diagram					
Item	Qty	Ordering no.	Denomination	Notes	C
1	1	0468 516 895	Mains cable (Only for CE & AUS versions)		
1	1	0468 516 905	Mains cable 4×10 AWG (Only for CSA version)		
1	1	0468 516 904	Mains cable 4×6 mm ² (Only for CCC version)		
1A	1	0349 891 208	Plug	Only for CE & AUS versions	
2	2	0194 034 003	Ring core ferrite		
3	1	0349 312 063	Ring core ferrite		
4	1		Cable tie		
6	1	0465 515 003	Decals mains voltage setting	Only for CE, CCC & AUS	
6	1	0465 515 001	Decals mains voltage setting	Only for CSA	
7	1	0465 419 004	Warning decal power source	Only for CSA	

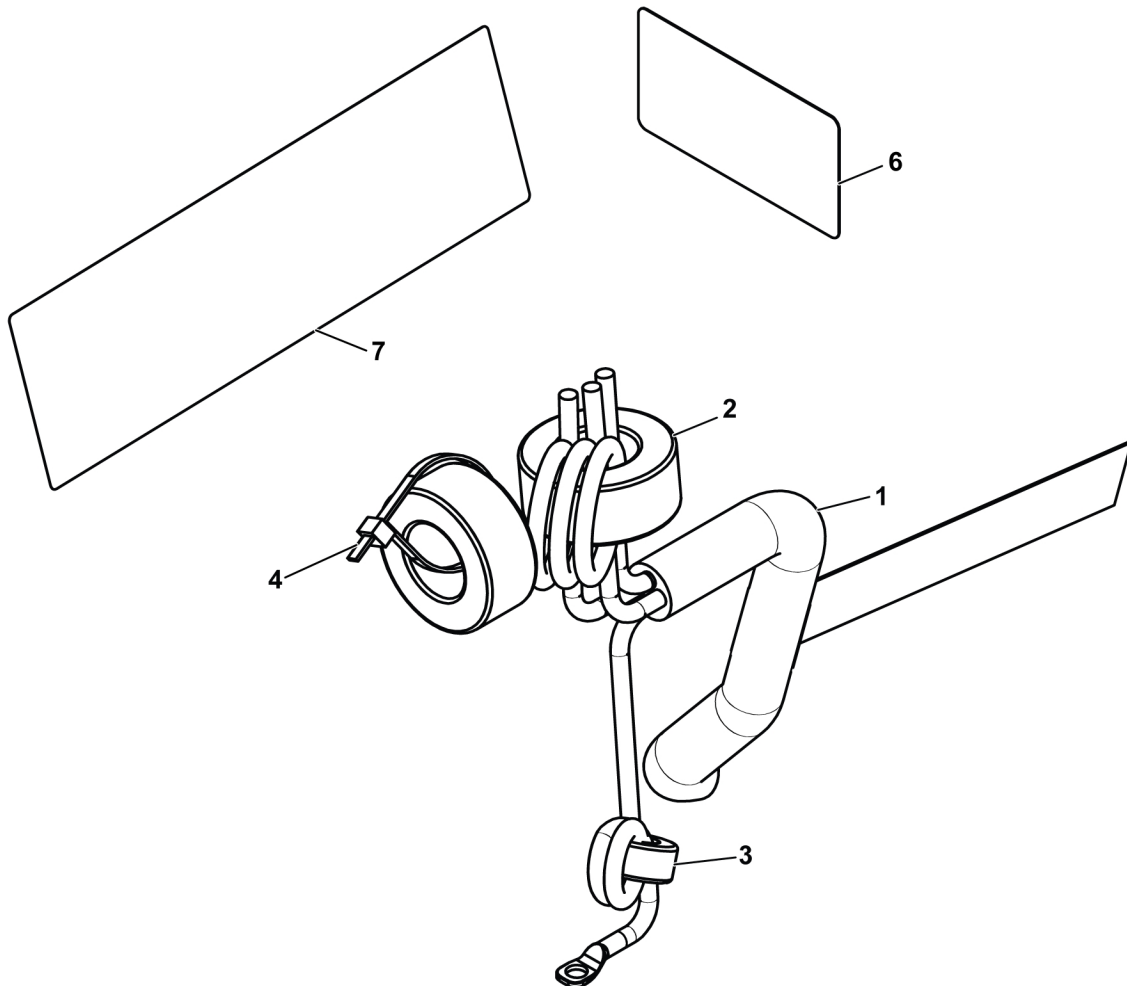



A WORLD OF PRODUCTS AND SOLUTIONS.



For contact information visit <http://esab.com>

ESAB AB, Lindholmsallén 9, Box 8004, 402 77 Gothenburg, Sweden, Phone +46 (0) 31 50 90 00

manuals.esab.com

